

Electronically Commutated Motors

As a professional electric motors manufacturer who cares about environment and energy most important goals is to saving, one of our help our partners to reduce total life operation costs, increase profitability and make production more environmentally friendly.

TECHTOP EC (Electronically Commutated) motors is the special designed PMS (permanent magnet synchronous) motors which constructed on the base of the IEC norm, it is now available in four frame sizes IEC-71#, IEC-90#, IEC-100#, IEC-132#, the maximum output is 22kW and the maximum torque is 70Nm.



To be qualified for the next generation which requires for higher energy saving products, TECHTOP EC motors has the following advantages:

- Extremely high efficiency, the average value reaches IE5 standard.
- Extremely high efficiency over a wide speed and power range.
- Compact and lightweight design with higher power density.
- The mounting dimensions comply with IEC standards and make it easy to change from standard AC motors to EC motors.
- Various and flexible mounting types suitable for different applications.

Motor contain three series:

• ECI

T – IEC frame size 71# to 132# permanent magnet synchronous motors with integrated drive.

F – IEC frame size 80# to 112# permanent magnet synchronous motors with integrated drive.

• EC

T – IEC frame size 71# to 132# permanent magnet synchronous motors



Product Brief

EC motors are permanent magnet synchronous motors specially designed according to IEC standards. EC motors will be used in the next generation where more energy efficient products are required. Exceeds IEC 60034-30-2-2016 “Energy Efficiency Classes for AC Speed Motors” .

EC motors lead the way in the next generation of motor efficiency and performance technology.

Motor contain three series:

- T-EC series – Permanent magnet synchronous motor.
- T-ECI series – Permanent magnet synchronous motor integrated drive.
- F-ECI series – Permanent magnet synchronous motor integrated drive.

Model number nomenclature

T **100** **EC** **14** **G** **36** **C2** **B14** **T1** **F**
 1 2 3 4 5 6 7 8 9 10

Position	Character	Description
1	“T”	Product platform
2	“100”	Frame size: IEC 71, 80, 90, 100, 112, 132
3	“EC”	EC: permanent magnet motor ECI: permanent magnet motor with integrated drive
4	“14”	Rated torque: 14 = 14Nm
5	“G”	Cooling method: G = IC411-TEFC Totally enclosed motor fan cooled (own fan ventilation). V = IC418-TEAO Totally enclosed motor air over (no fan-motor in air stream). N = IC410-TENV Totally enclosed motor naturally ventilated (no fan). F = IC416-TEFV Totally enclosed motor with independent fan.
6	“36”	Maximum speed: 36 = 3600 rpm
7	C2	Power line connection method: T1 = Terminal box on top T2 = Terminal box on NDE C1 = No terminal box, power line from housing C2 = No terminal box, power line from NDE
8	B14	Mounting method: B3, B13, B14, B5, B34, B35, B14B, B5R, B30
9	T1	Voltage code: T1 = 3PH, 360-460 V or 380-480V, ± 10% T2 = 3PH, 200-240V or 200-277V T3 = 3PH, 400/230V S1 = 1PH, 200-240V or 200-277V S2 = 1PH, 115V S3 = 1PH, 230 or 115V dual voltage
10	F	Special requirement: F = Internal protector

T-EC series



Model list

Frame	Maximum speed (r/min)	Power (kW)	Rated torque (N.m)	Model
T71-EC	600	0.08	1.2	T17EC01X
		0.15	2.4	T17EC02X
		0.20	3.2	T17EC03X
	900	0.11	1.2	T17EC01X
		0.23	2.4	T17EC02X
		0.30	3.2	T17EC03X
	1500	0.19	1.2	T71EC01X
		0.38	2.4	T71EC02X
		0.50	3.2	T71EC03X
	1800	0.23	1.2	T71EC01X
		0.45	2.4	T71EC02X
		0.60	3.2	T71EC03X
	3000	0.38	1.2	T71EC01X
		0.75	2.4	T71EC02X
		1.00	3.2	T71EC03X
3600	0.45	1.2	T71EC01X	
	0.90	2.4	T71EC02X	
	1.21	3.2	T71EC03X	
T90-EC	600	0.20	3.2	T90EC03X
		0.31	5	T90EC05X
		0.44	7	T90EC07X
T90-EC	900	0.30	3.2	T90EC03X
		0.47	5.0	T90EC05X
		0.66	7.0	T90EC07X
	1500	0.50	3.2	T90EC03X
		0.79	5.0	T90EC05X
		1.10	7.0	T90EC07X
	1800	0.60	3.2	T90EC03X
		0.94	5.0	T90EC05X
		1.32	7.0	T90EC07X
	3000	1.00	3.2	T90EC03X
		1.57	5.0	T90EC05X
		2.20	7.0	T90EC07X
	3600	1.21	3.2	T90EC03X
		1.88	5.0	T90EC05X
		2.64	7.0	T90EC07X

Model list

Frame	Maximum speed (r/min)	Power (kW)	Rated torque (N.m)	Model
T100-EC	600	0.63	10	T100EC10X
		0.88	14	T100EC14X
		1.19	19	T100EC19X
	900	0.94	10.0	T100EC10X
		1.32	14.0	T100EC14X
		1.79	19.0	T100EC19X
	1500	1.57	10.0	T100EC10X
		2.20	14.0	T100EC14X
		2.98	19.0	T100EC19X
	1800	1.88	10.0	T100EC10X
		2.64	14.0	T100EC14X
		3.58	19.0	T100EC19X
	3000	3.14	10.0	T100EC10X
		4.40	14.0	T100EC14X
		5.97	19.0	T100EC19X
		3.77	10.0	T100EC10X
		5.28	14.0	T100EC14X
		7.16	19.0	T100EC19X
3600	1.63	26.0	T132EC26X	
	2.20	35.0	T132EC35X	
	3.01	48.0	T132EC48X	
T132-EC	600	3.71	59.0	T132EC59X
		4.40	70.0	T132EC70X
		2.45	26.0	T132EC26X
	900	3.30	35.0	T132EC35X
		4.52	48.0	T132EC48X
		5.56	59.0	T132EC59X
		6.59	70.0	T132EC70X
		4.08	26.0	T132EC26X
	1500	5.50	35.0	T132EC35X
		7.54	48.0	T132EC48X
		9.26	59.0	T132EC59X
		10.99	70.0	T132EC70X
		4.90	26.0	T132EC26X
	1800	6.59	35.0	T132EC35X
		9.04	48.0	T132EC48X
		11.12	59.0	T132EC59X
		13.19	70.0	T132EC70X
		8.17	26.0	T132EC26X
3000	10.99	35.0	T132EC35X	
	15.07	48.0	T132EC48X	
	18.53	59.0	T132EC59X	
3000	21.98	70.0	T132EC70X	

E C motor efficiency comparison with IE5

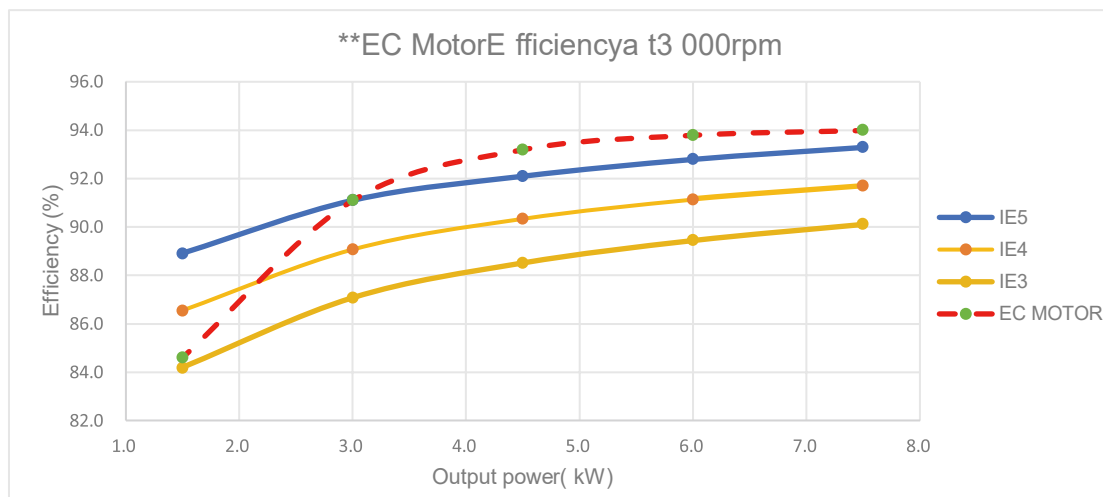

EC motor application - Inverter and motor connection

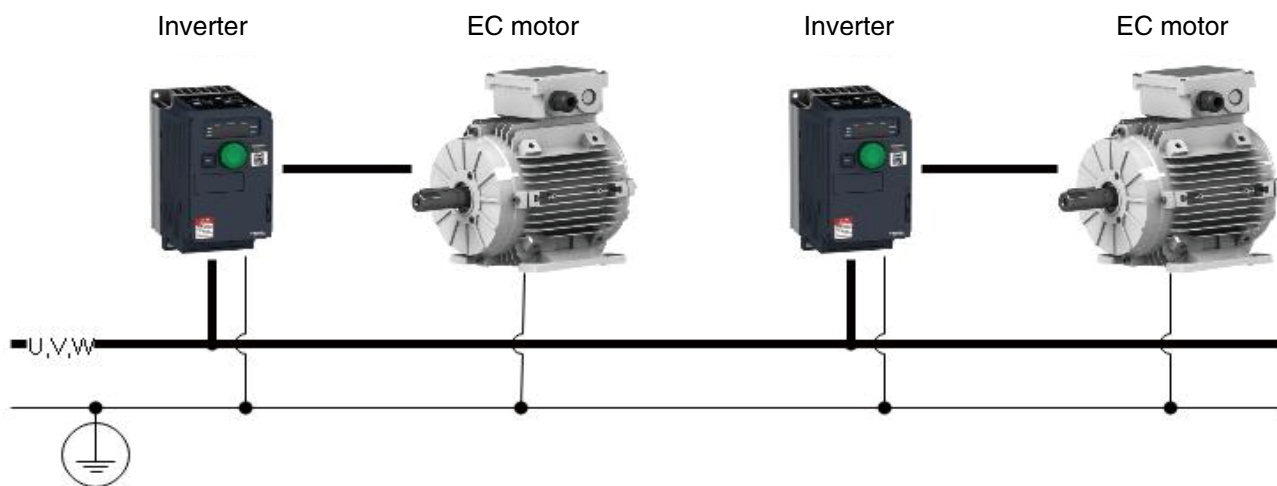

EC motor parameters for inverter

PMSM must drive by the VSD. The motor cannot connect to the normal AC power directly. The VSD can be the commercial drive with vector control or PM motor control mode. VSD need to be set the correct motor parameter (see below table). The detail parameters can be find in the model data sheet. (T100EC19X36 model such as a sample)

Items	Y	Δ	Unit	Note
Inverter input voltage:	360-460	360-460	V	
Pole numbers:	6	6		
Max speed:	1800	3600 rpm	rpm	
Max frequency:	90	180	Hz	
VSD output voltage:	360	360	V	Minimum
Max current:	8.75	15.5	A	
Max output power:	4500	9000	w	
Resistance:	0.67	0.22	Ohm	Phase
Ld:	11.60	3.87	mH	Phase
Lq:	24.00	8.00	mH	Phase
Back EMF value:	111	65	L-N Vrms per 1000 rpm	

*The detail model parameters please check Data sheet for each model.

E C motor running power range

Different cooling condition the motor power range will be different
(T100EC19X36 model such as a sample)

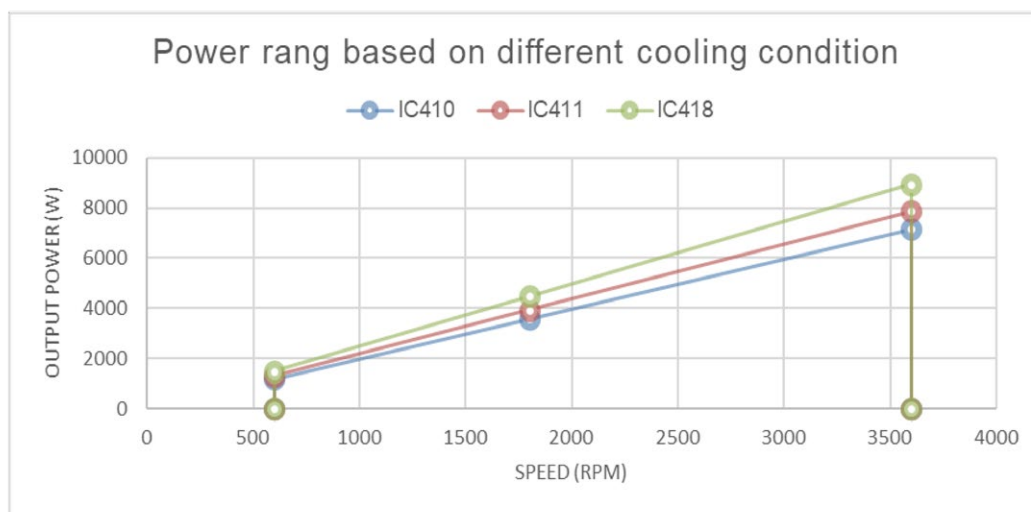

E C motor nameplates

- * Good cooling allows the motor to operate in a higher power range. IC411 is 1.1 times that of IC410, and when operating under conditions of IC418, the airflow through the motor surface should be maintained at not less than 3 m/s under rated load.
- * S2 or other duty cycle can reach higher power based on the duty cycle value.

ECHTOP [®] MOTOR				IE5 CE IEC 60034-1		
Serial n° :		*****				
Model or type :		T132EC70G30T1B35T1F				
Rate torque :		70N.m(40-200Hz)				
Inverter voltage :		360-460V@50/60Hz				
Duty:S1	INS.CL.F	IP55	8P	Temp. Ambient:-25°C - +40°C		
Con.	Hz	r/min	A	kW	Cos Φ	Eff.
Y	120	1800	23.9	13.2	0.89	94.3%
Δ	200	3000	41.4	22.0	0.86	94.3%
IMAX=23.9A(Y),41.4A(Δ)				IC411/TEFC		
BEMF=377V(Y),364V(Δ)				Weight:56.8kg		
DE:6308ZZ/C3,NDE:6208ZZ/C3				Manufacturer Date:*****		

Remark:

The format of the rating plate is for reference only. The final data will be subject to the actual rating plate.

E C motor machinal dimension

• EC 100

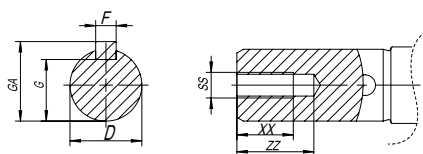

Shaft size

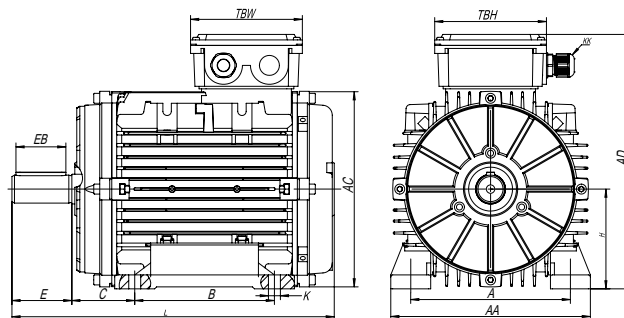

B3

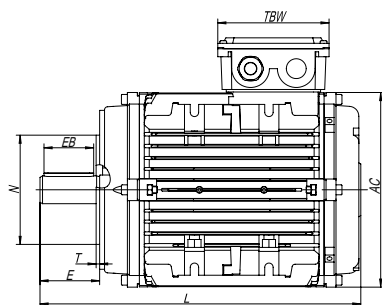

B14

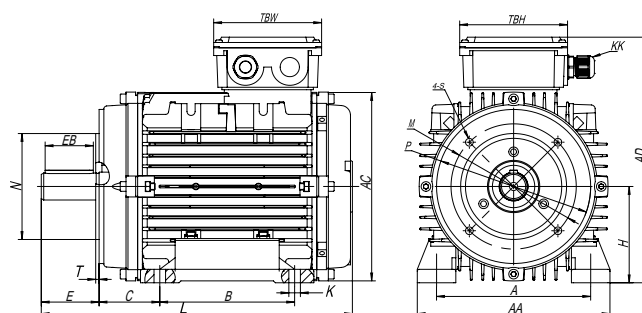

B34

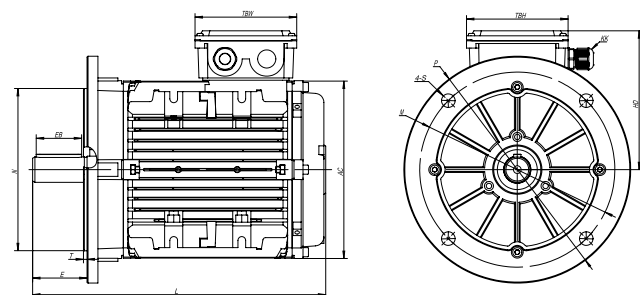

B5

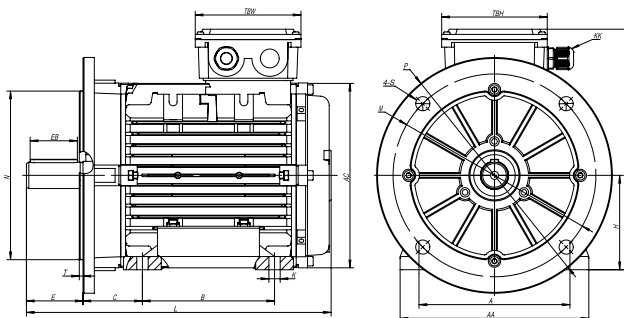

B35

Frame	Foot Mounting				Shaft									General								
	H	A	B	C	D	E	F	G	K	SS	EB	XX	ZZ	AA	AD	HD	AC		L		TBW	TBH
																	IC410	IC411	IC410	IC411		
71	71	112	90	45	Φ14	30	5	11	7×10	M5	22	12	17	140	189	118	Φ136	Φ138	208	245	94	94
90	90	140	100	56	Φ24	50	8	20	10×15	M8	40	19	25	175	235	145	Φ175	Φ177	244	315	105	105
100	100	160	140	63	Φ28	60	8	24	12×16	M10	50	22	30	200	255	155	Φ197	Φ199	323	376	112	112
132	132	216	140	89	Φ38	80	10	33	12×16	M12	70	28	37	260	318	186	Φ259	Φ261	395	460	112	112

Frame	KK	B5					B14					B5R					B14B				
		N	M	P	S	T	N	M	P	S	T	N	M	P	S	T	N	M	P	S	T
71	1-M20×1.5	Φ110	Φ130	Φ160	Φ10	3.5	Φ70	Φ85	Φ105	M6	2.5	Φ95	Φ115	Φ140	Φ10	3	Φ95	Φ115	Φ140	M8	3
90	1-M20×1.5	Φ130	Φ165	Φ200	Φ12	3.5	Φ95	Φ115	Φ140	M8	3	Φ110	Φ130	Φ160	Φ10	3.5	Φ110	Φ130	Φ160	M8	3.5
100	1-M20×1.5	Φ180	Φ215	Φ250	Φ15	4	Φ110	Φ130	Φ160	M8	3.5	Φ130	Φ165	Φ200	Φ12	3.5	Φ130	Φ165	Φ200	M10	3.5
132	1-M25×1.5	Φ230	Φ265	Φ300	Φ15	4	Φ130	Φ165	Φ200	M10	3.5	Φ180	Φ215	Φ250	Φ15	4	Φ180	Φ215	Φ250	M12	4

T-ECI series

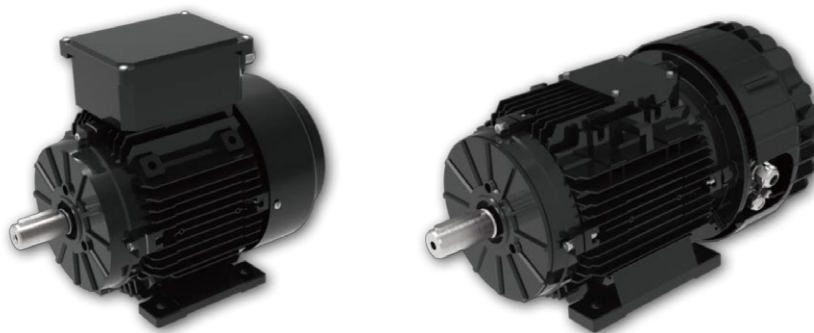

Model list

Frame	Maximum speed (r/min)	Power (kW)	Rated torque (N.m)	Model
T71-ECI	Single-phase, 200-240V or 200-277V, 50/60 Hz			
	1500	0.19	1.2	T71ECI01
		0.38	2.4	T71ECI02
		0.50	3.2	T71ECI03
	1800	0.23	1.2	T71ECI01
		0.45	2.4	T71ECI02
		0.60	3.2	T71ECI03
	3000	0.75	2.4	T71ECI02
		1.00	3.2	T71ECI03
	3600	0.45	1.2	T71ECI01
T90-ECI	Single-phase, 200-240V or 200-277V, 50/60 Hz			
	600	0.20	3.2	T90ECI03
		0.31	5.0	T90ECI05
		0.44	7.0	T90ECI07
	900	0.30	3.2	T90ECI03
		0.47	5.0	T90ECI05
		0.66	7.0	T90ECI07
		0.50	3.2	T90ECI03
	1500	0.79	5.0	T90ECI05
		1.10	7.0	T90ECI07
		0.60	3.2	T90ECI03
	1800	0.94	5.0	T90ECI05
		1.32	7.0	T90ECI07
		1.00	3.2	T90ECI03
		1.57	5.0	T90ECI05
	3000	2.20	7.0	T90ECI07
		Single-phase, 200-240V or 200-277V, 50/60 Hz		
T100-ECI	600	0.63	10.0	T100ECI10
		0.75	12.0	T100ECI12
	900	0.94	10.0	T100ECI10
		1.13	12.0	T100ECI12
	1500	1.57	10.0	T100ECI10
		1.88	12.0	T100ECI12
	1800	1.88	10.0	T100ECI10
	Three-phase, 360-460V or 380-480 ± 10%, 50/60 Hz			
	600	0.63	10.0	T100ECI10
		0.88	14.0	T100ECI14
		1.19	19.0	T100ECI19
	900	0.94	10.0	T100ECI10
		1.32	14.0	T100ECI14
		1.79	19.0	T100ECI19
	1500	1.57	10.0	T100ECI10
		2.20	14.0	T100ECI14
		2.98	19.0	T100ECI19
1800	1.88	10.0	T100ECI10	
	2.64	14.0	T100ECI14	
	3.58	19.0	T100ECI19	
3000	3.14	10.0	T100ECI10	

IEC MOTOR

FIRE PUMP MOTOR

GOST MOTOR

VHS MOTOR

H.T. MOTOR

S.S. MOTOR

NEMA MOTOR

EC MOTOR

Model list

Frame	Maximum speed (r/min)	Power (kW)	Rated torque (N.m)	Model
T132-ECI	600	1.63	26.0	T132ECI26
		2.20	35.0	T132ECI35
		3.01	48.0	T132ECI48
	900	2.45	26.0	T132ECI26
		3.30	35.0	T132ECI35
	1300	3.54	26.0	T132ECI26

*Detailed data of the motor is shown in the data sheet, such as torque, current and efficiency.

*71 and 90 frame ECI motors are powered by single-phase power supplies, and 100- and 132-frame ECI motors are powered by three-phase power supplies, which can be customized to 380 to 480 V, $\pm 10\%$ and 200 to 277 V on some models.

*IC418-TEAO: The motor must be operated under forced air-cooled conditions with a minimum airflow of 3m/s through the motor frame and over the drive cover.

*IC416-TEFV: Optional configuration of independent fan cooling for T90ECI, T100ECI and T132ECI only.

ECI motor structure reference

ECI motor drive function

- CW/CCW choose
- Start-stop terminal
- 0-10VDC speed control
- RS485 Modbus
- Speed feedback



ECI motor nameplates

Single phase nameplates of ECI motor

ECHTOP [®] MOTOR		IE5		CE
IEC 60034-1				
Serial n° :		*****		
Model or type :		T100ECI10F18C2B34S1		
Voltage/frequency/phase :		200-277V,50/60Hz,1ph		
Rate torque and speed :		10N.m,300-1800rpm		
Nominal power and current :		1.88kW 14.8A @1800rpm		
System Eff.:		η 89.4% @1800rpm		
S1	IP54	INS CL. F/B	-25°C - +40°C	
Power terminal and cable		Control terminal and cable		
Line supply: Brown		Speed output: White		
Neutral: Blue		On/Off: Red		
PE: Yellow/Green		12VDC output: Yellow		
		0-10VDC input: Blue		
		Common: Black		
ON/OFF Control: Red+Yellow		Modbus: A-Green,B-Grey		
CW/CCW Control: Yellow+Brown		Fire mode: 1-Purple,2-Pink		

Three phase nameplates of ECI motor

ECHTOP [®] MOTOR		IE5		CE
IEC 60034-1				
Serial n° :		*****		
Model or type :		T100ECI10F30C2B5T1		
Voltage/frequency/phase :		360-460V,50/60Hz,3ph		
Rate torque and speed :		10N.m,600-3000rpm		
Nominal power and current :		3.14kW 5.5A @3000rpm		
System Eff.:		η 91.9% @3000rpm		
S1	IP54	INS CL. F/B	-25°C - +40°C	
Power terminal and cable		Control terminal and cable		
L1: Brown		Speed output: White		
L2: Black		On/Off: Red		
L3: Grey		12VDC output: Yellow		
PE: Yellow/Green		0-10VDC input: Blue		
		Common: Black		
ON/OFF Control: Red+Yellow		Modbus: A-Green,B-Grey		
CW/CCW Control: Yellow+Brown		Fire mode: 1-Purple,2-Pink		

Remark:

The format of the rating plate is for reference only. The final data will be subject to the actual rating plate.

E CI motor structure reference

Motors and Exploded Drawings (IC418-TEAO)

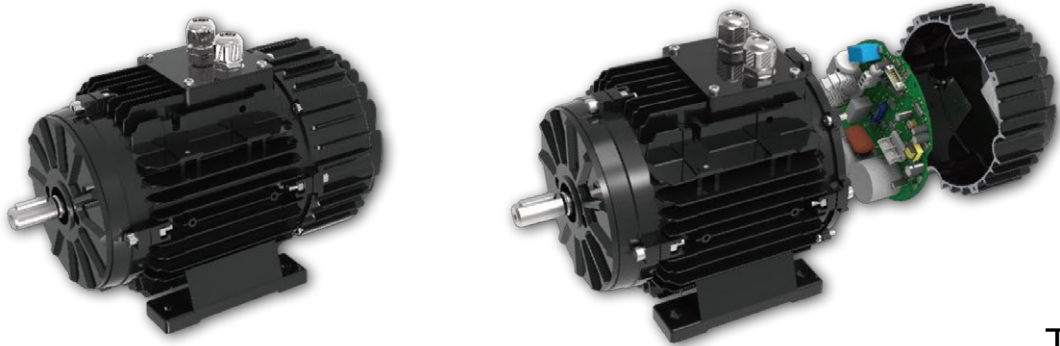

T71ECI

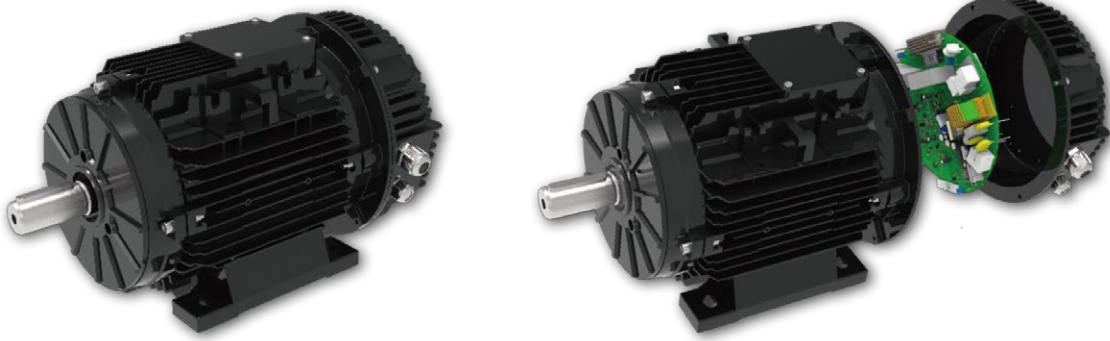

T100ECI

Motors and Exploded Drawings (IC416-TEFV)

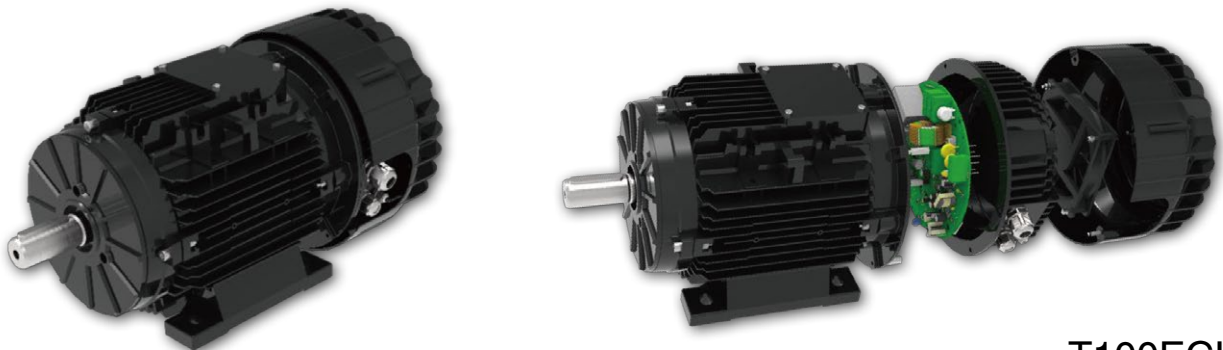

T100ECI

IEC MOTOR

FIRE PUMP MOTOR

GOST MOTOR

VHS MOTOR

H.T. MOTOR

S.S. MOTOR

NEMA MOTOR

EC MOTOR

ECI motor control function

Terminal control function

The drive is equipped with functions such as run/stop, CW/CCW, and VSP/PWM speed adjustment, as well as speed feedback signal FG, alarm switch signal FO (optional), and fire signal (optional). Customers can use these control signals to adjust speed, start and stop ECI motors, ensuring they have appropriate rotation direction and speed. They can simultaneously understand the working status of the motor through alarm signals.

Modbus control function

ECI motor is equipped with MODBUS communication control function, which can control the starting and ending of the motor, speed regulation, steering regulation, frequency hopping, identifying error signals of motor and collect output signals of the driver through communication protocol.

The independent fan at the end of the motor can adjust the start/stop time according to the difference in heat generation of different loads.

Three-phase motor power line

Item	Fuction	Wire color	Note
1	L1	Brown	Three phase power
2	L2	Black	Three phase power
3	L3	Grey	Three phase power
4	PE	Yellow/Green	

Wiring diagram of three-phase motor

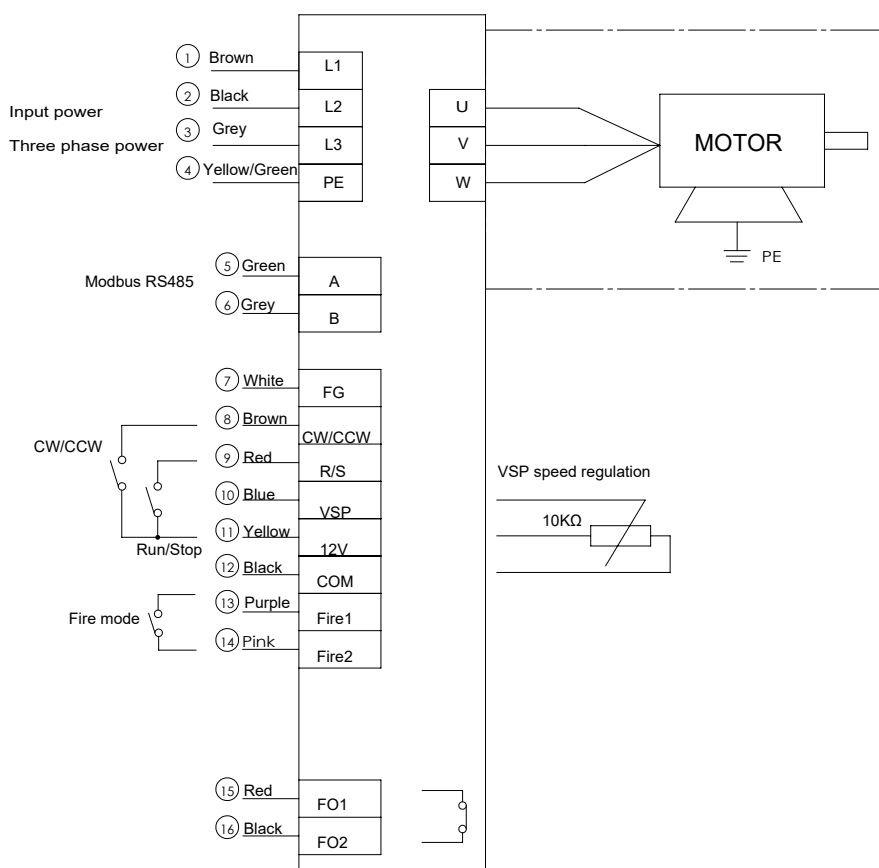

Single-phase motor power line

Item	Fuction	Wire color	Note
1	L	Brown	Single phase power
2	N	Blue	Single phase power
3	PE	Yellow/Green	

Wiring diagram of single-phase motor

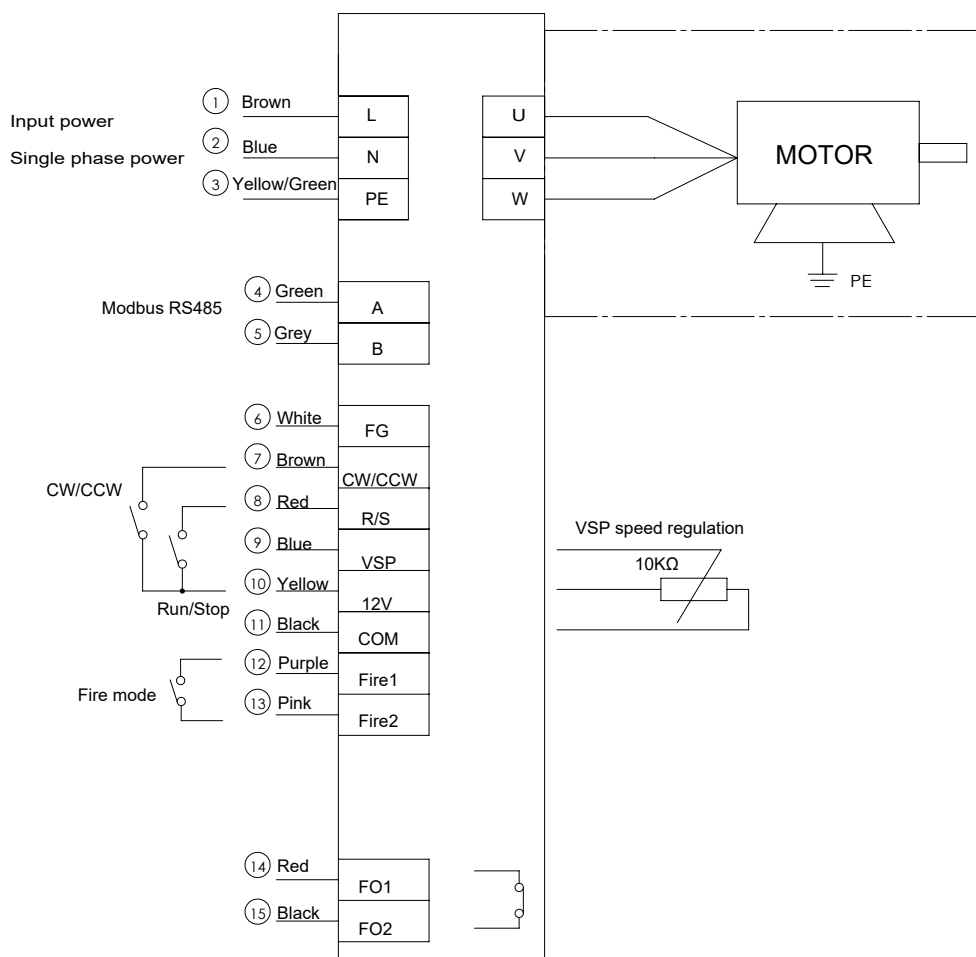

ECI motor control line definition

Item	Fuction	Wire color	Note
5	RS485 A	Green	Modbus 485
6	RS485 B	Grey	Modbus 485
7	FG	White	3 puls per rev
8	CW/CCW	Brown	CW: Brown, CCW: Brown + Yellow
9	Run/Stop	Red	Run: Red + Yellow
10	VSP	Blue	Speed control
11	DC 12V output	Yellow	
12	COM	Black	
13	PWM	Orange	Optional (T71 and T90 only)
14	Fire 1	Purple	Optional
15	Fire 2	Pink	Optional
16	FO 1	Red	Optional
17	FO 2	Black	Optional

E IEC motor machinal dimension (IC418-TEAO)

•71ECI

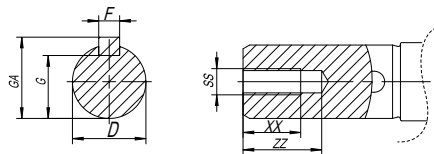

Shaft size

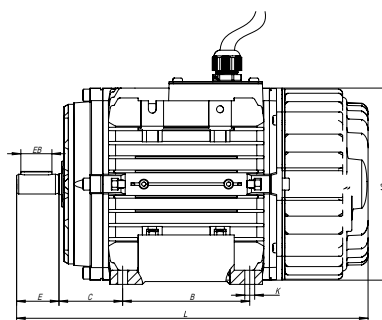

B3

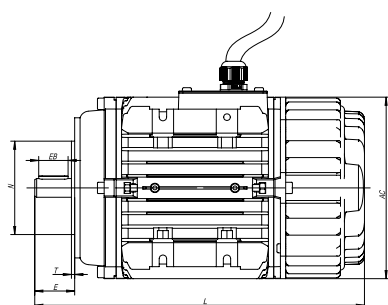
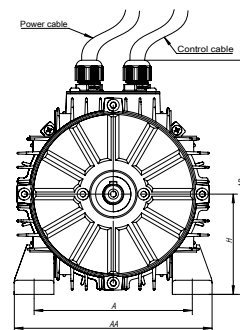

B14

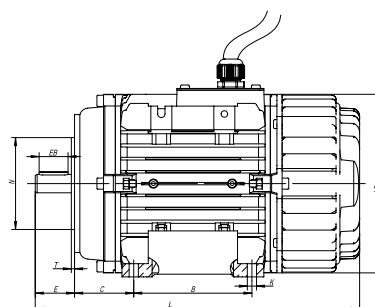
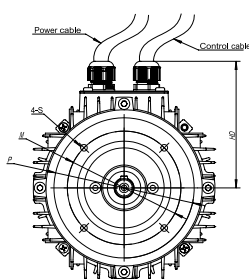

B34

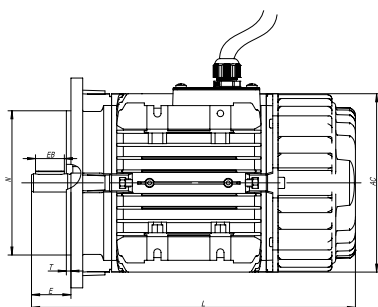
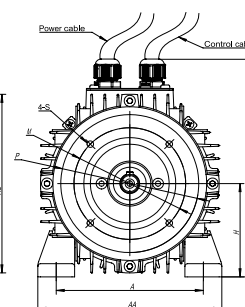

B5

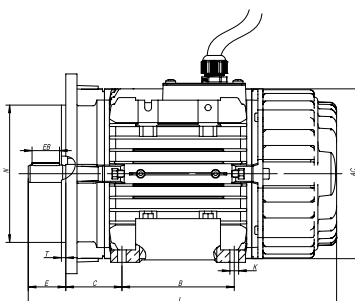
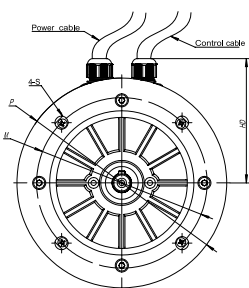

B35

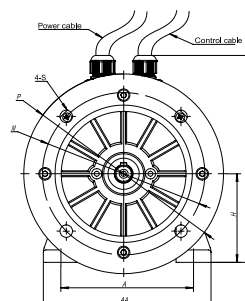

•90ECI

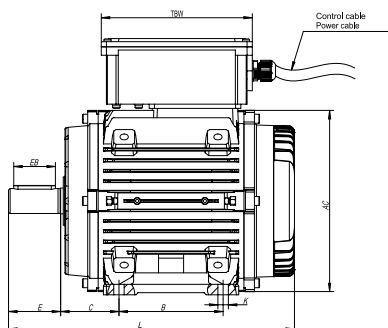

B3

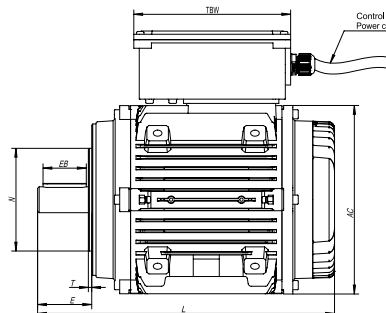
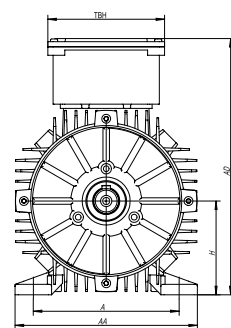

B14

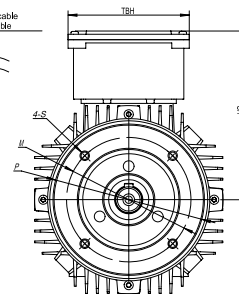

E CI motor machinal dimension (IC418-TEAO)

•90ECI

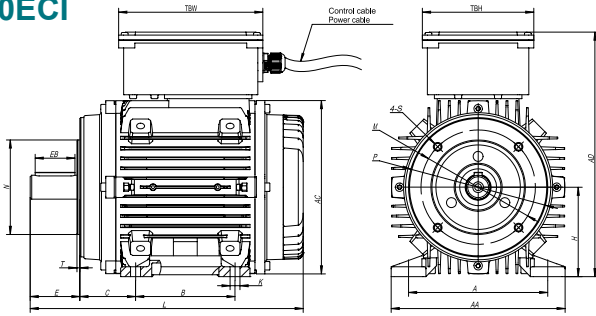

B34

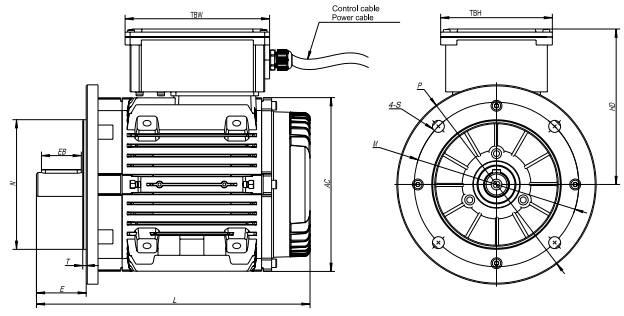

B5

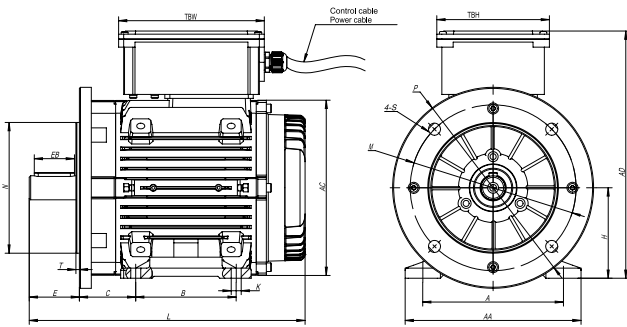

B35

•100ECI

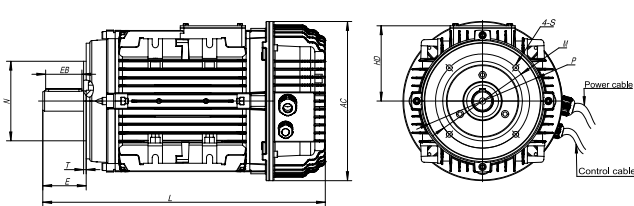

B14

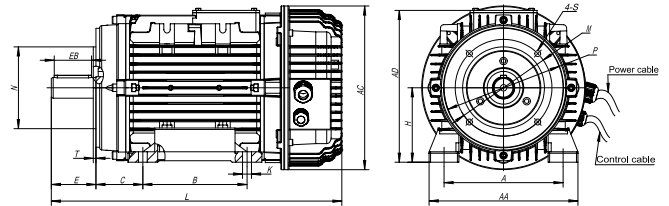

B34

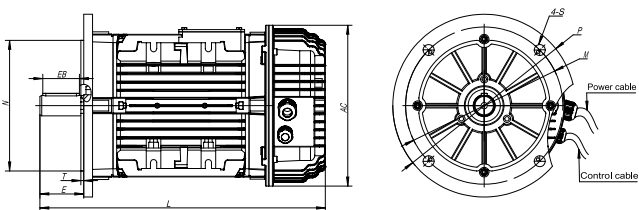

B5

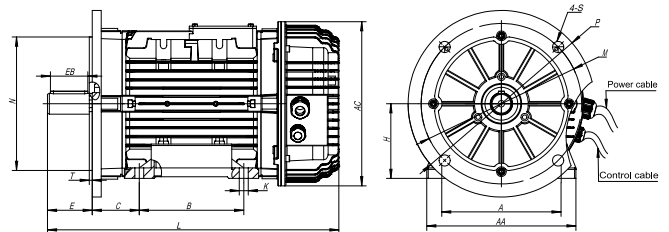

B35

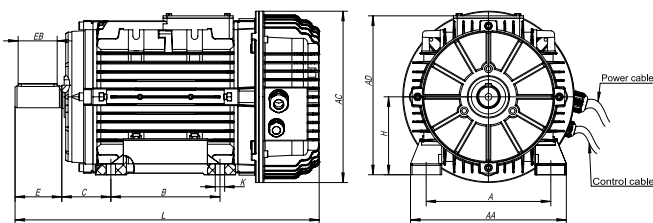

B3

ECI motor machinal dimension (IC418-TEAO)

•132ECI

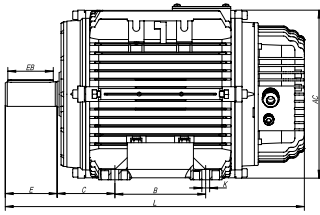

B3

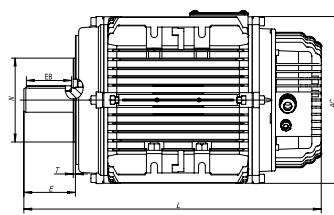
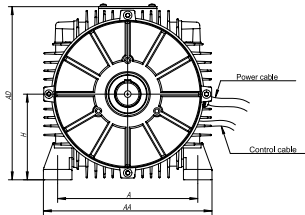

B14

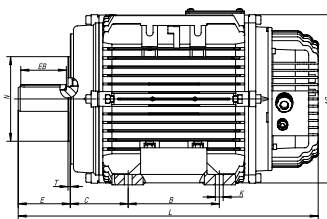
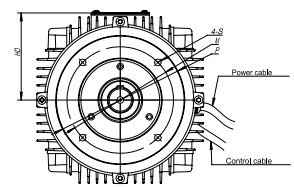

B34

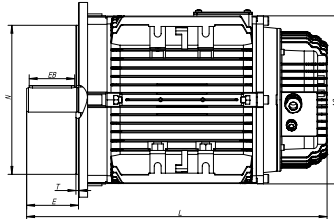
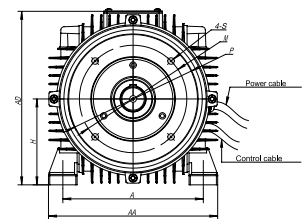

B5

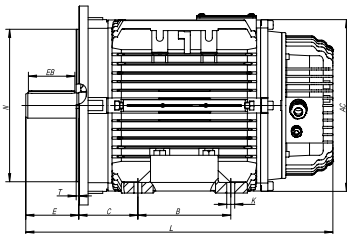
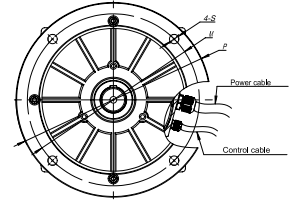

B35

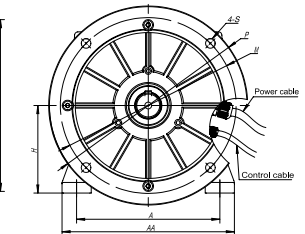

Frame	Foot Mounting				Shaft									General				
	H	A	B	C	D	E	F	G	K	SS	EB	XX	ZZ	AA	AD	HD	AC	L
71	71	112	90	45	Φ14	30	5	11	7 × 10	M5	22	12	17	140	168	95	Φ136	247
90	90	140	100	56	Φ24	50	8	20	10 × 15	M8	40	19	25	175	248	156	Φ175	275
100	100	160	140	63	Φ28	60	8	24	12 × 16	M10	50	22	30	200	208	108	Φ220	390.5
132	132	216	140	89	Φ38	80	10	33	12 × 16	M12	70	28	37	260	269	137	Φ259	463

Frame	B5					B14					B5R					B14B				
	N	M	P	S	T	N	M	P	S	T	N	M	P	S	T	N	M	P	S	T
71	Φ110	Φ130	Φ160	Φ10	3.5	Φ70	Φ85	Φ105	M6	2.5	Φ95	Φ115	Φ140	Φ10	3	Φ95	Φ115	Φ140	M8	3
90	Φ130	Φ165	Φ200	Φ12	3.5	Φ95	Φ115	Φ140	M8	3	Φ110	Φ130	Φ160	Φ10	3.5	Φ110	Φ130	Φ160	M8	3.5
100	Φ180	Φ215	Φ250	Φ15	4	Φ110	Φ130	Φ160	M8	3.5	Φ130	Φ165	Φ200	Φ12	3.5	Φ130	Φ165	Φ200	M10	3.5
132	Φ230	Φ265	Φ300	Φ15	4	Φ130	Φ165	Φ200	M10	3.5	Φ180	Φ215	Φ250	Φ15	4	Φ180	Φ215	Φ250	M12	4

E CI motor machinal dimension (IC416-TEFV)

•90ECI

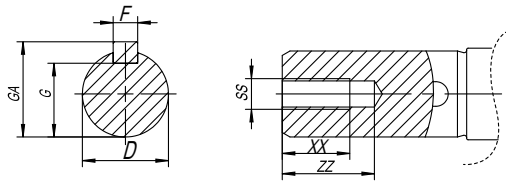

Shaft size

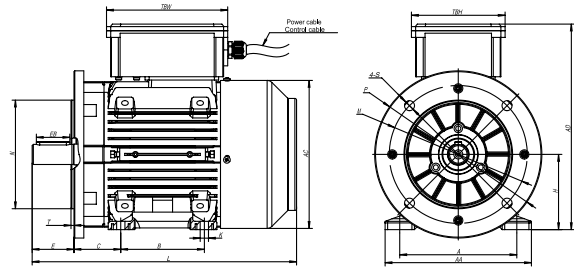

B35

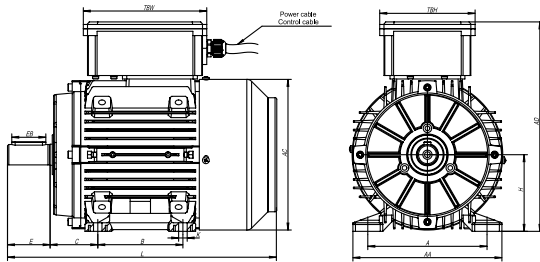

B3

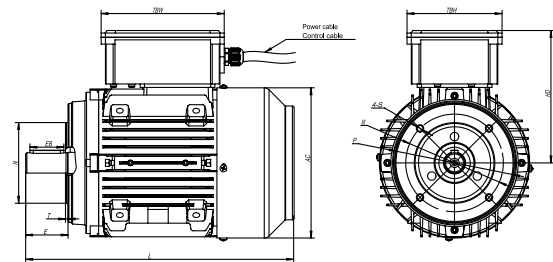

B14

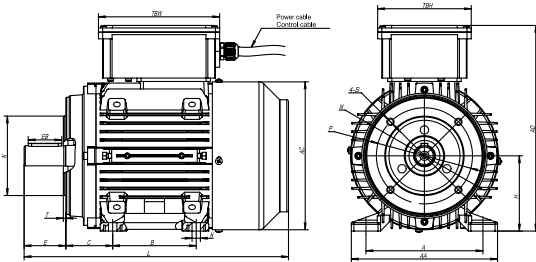

B34

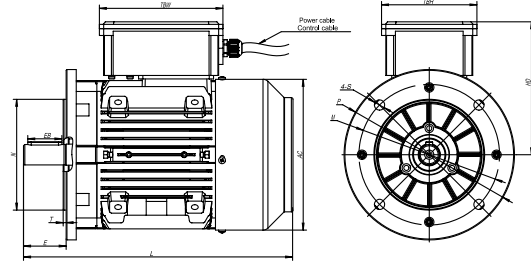

B5

•100ECI

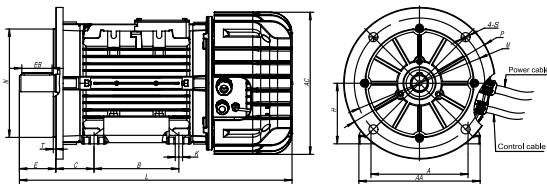

B35

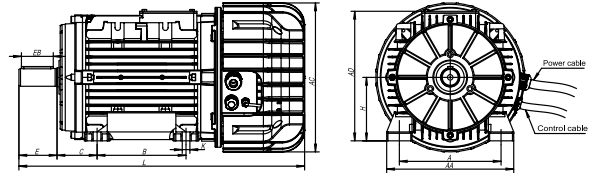

B3

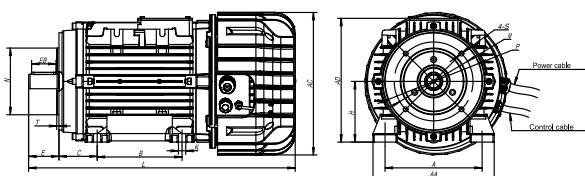

B34

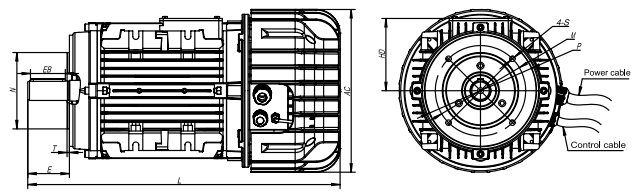

B14

E CI motor machinal dimension (IC416-TEFV)

•100ECI

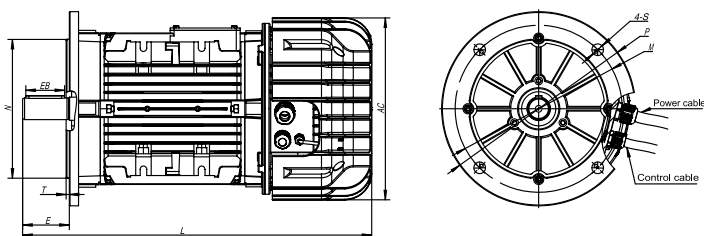

B5

•132ECI

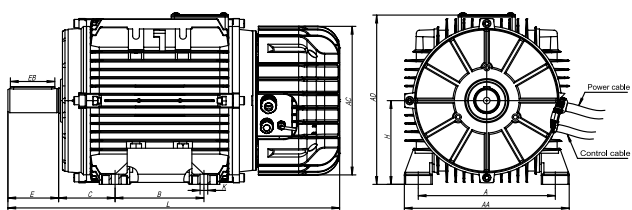

B3

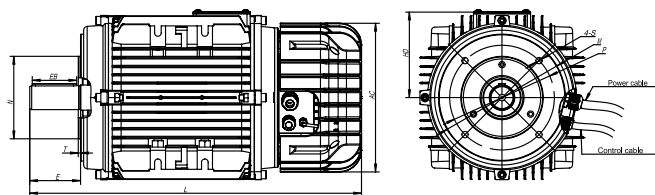

B14

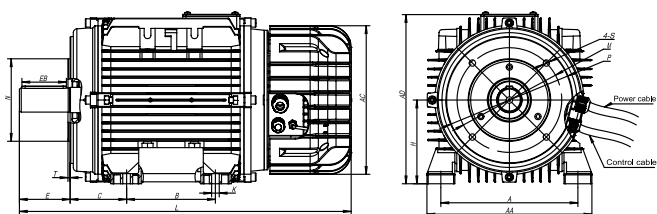

B34

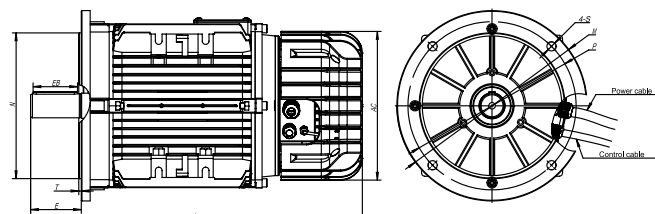

B5

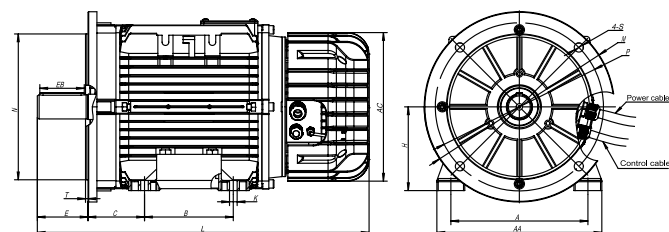

B35

Frame	Foot Mounting				Shaft									General			
	H	A	B	C	D	E	F	G	K	SS	EB	XX	ZZ	AC		L	
														IC416	IC418	IC416	IC418
71	71	112	90	45	Φ14	30	5	11	7 × 10	M5	22	12	17	/	Φ136	/	247
90	90	140	100	56	Φ24	50	8	20	10 × 13	M8	40	19	25	Φ177	Φ175	316	275
100	100	160	140	63	Φ28	60	8	24	12 × 16	M10	50	22	30	Φ235	Φ220	449	390
132	132	216	140	89	Φ38	80	10	33	12 × 16	M12	70	28	37	Φ235	Φ259	523	463

Frame	B5					B14					B5R					B14B				
	N	M	P	S	T	N	M	P	S	T	N	M	P	S	T	N	M	P	S	T
71	Φ110	Φ130	Φ160	Φ10	3.5	Φ70	Φ85	Φ105	M6	2.5	Φ95	Φ115	Φ140	Φ10	3	Φ95	Φ115	Φ140	M8	3
90	Φ130	Φ165	Φ200	Φ12	3.5	Φ95	Φ115	Φ140	M8	3	Φ110	Φ130	Φ160	Φ10	3.5	Φ110	Φ130	Φ160	M8	3.5
100	Φ180	Φ215	Φ250	Φ15	4	Φ110	Φ130	Φ160	M8	3.5	Φ130	Φ165	Φ200	Φ12	3.5	Φ130	Φ165	Φ200	M10	3.5
132	Φ230	Φ265	Φ300	Φ15	4	Φ130	Φ165	Φ200	M10	3.5	Φ180	Φ215	Φ250	Φ15	4	Φ180	Φ215	Φ250	M12	4