

### 3. UDL 무단 변속기

### UDL SERIES PLANETARY CONE & DISK STEP-LESS SPEED VARIATOR

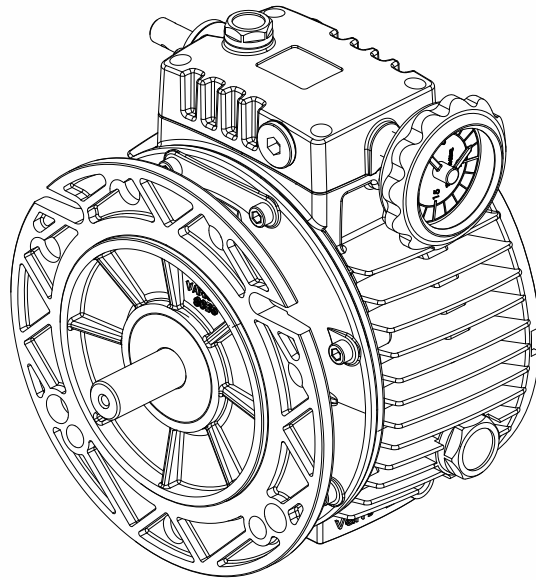

**UDL..B5**

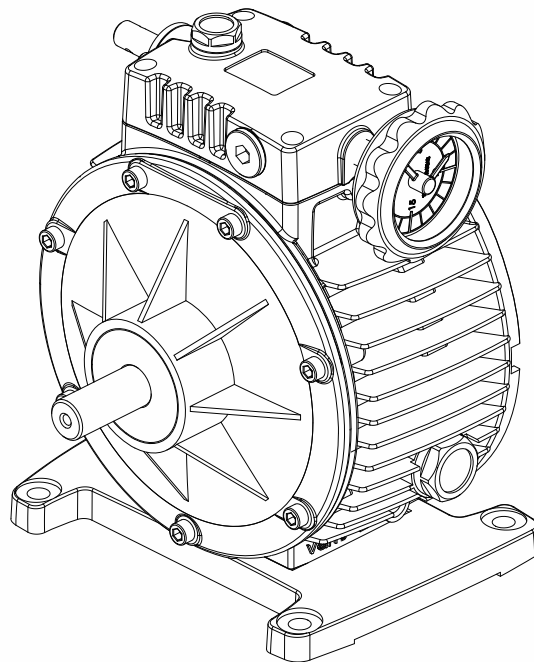

**UDL..B3**

3.1. 변속기 분해도

3.1. Exploded view

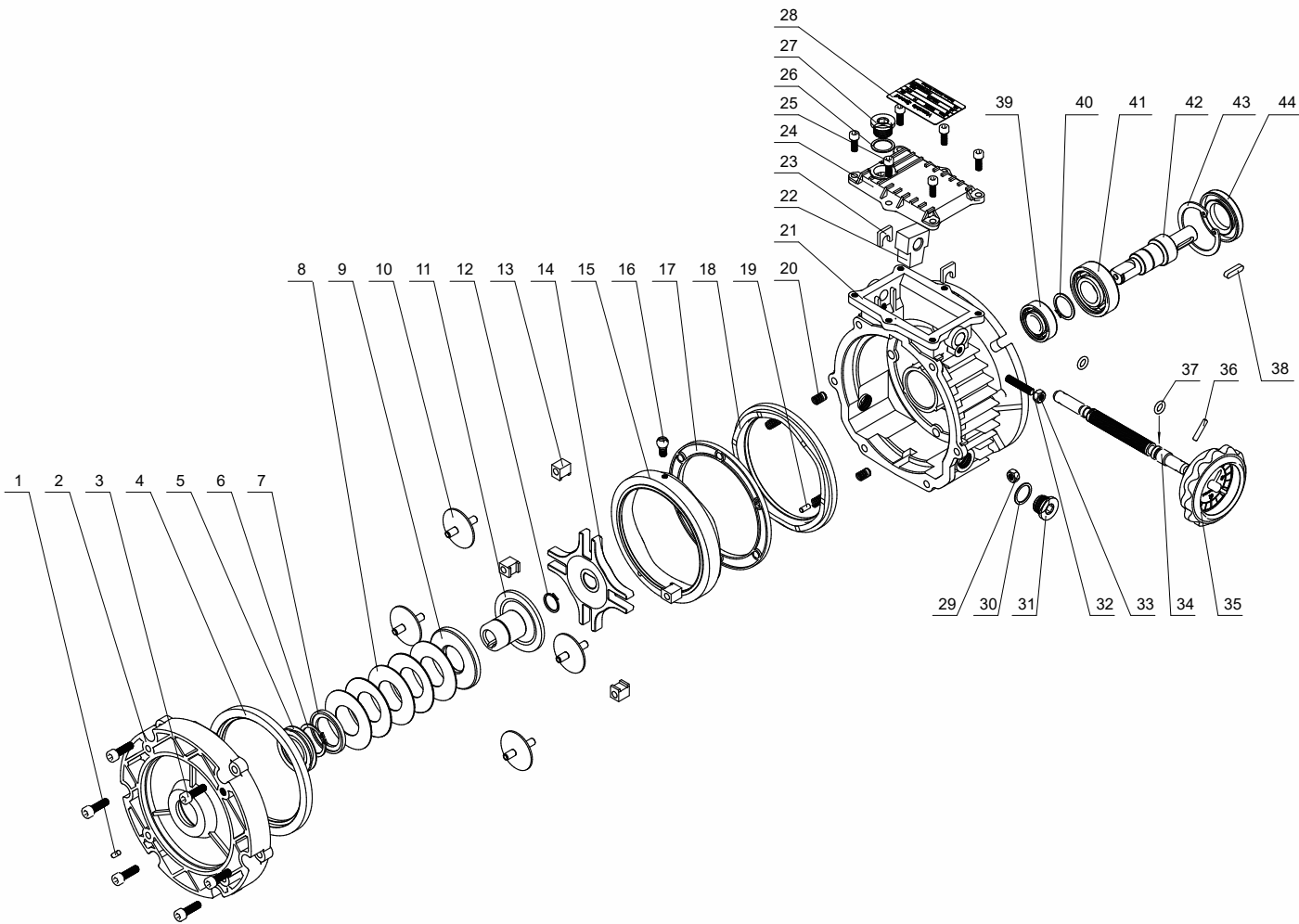

1	일자 핀 straight pin	12	스냅 링 (샤프트) Circlip for shaft	23	위치 피스 Locating piece	34	조절 나사로드 Regulating screw rod
2	입력 플렌지 Input Flange	13	플래닛 디스크 마찰 베어링 Planet disc friction bearing	24	캡 Cap	35	핸드 휠 Handwheel
3	헥사곤 소켓 헤드캡 스크류 Hexagon socket head cap screw	14	플래닛 캐리어 Planet carrier	25	헥사곤 소켓 헤드캡 스크류 Hexagon socket head cap screw	36	일자 핀 straight pin
4	고정 고리 레이스 Fixed annulus race	15	조정 가능 고리 레이스 Adjustable annulus race	26	루버 게스킷 Rubber gasket	37	오링 o-ring
5	오일실 oli seal	16	볼 조인트 Ball jjoint	27	오일 플러그 oil plug	38	평행 키 Parallel key
6	스냅 링 (샤프트) Circlip for shaft	17	볼링 Ball ring	28	명판 Nameplate	39	베어링 Bearing
7	와셔 Washer	18	캠 링 Cam ring	29	헥사곤 너트 Hexagon nuts	40	스냅 링 Circlip for hole
8	Belleville 스프링 Belleville spring	19	일자 핀 straight pin	30	루버 인서트 Rubber insert	41	베어링 Bearing
9	조정가능한 선 레이스 Adjustable sun race	20	스프링 spring	31	오일 게이지 Oil level indicator	42	출력 샤프트 Low speed shaft
10	플래닛 디스크 Planet disc	21	케이스 Case	32	볼트 Bolt	43	스냅 링 Circlip for hole
11	고정 선 레이스 Fixed sun race	22	조정 블록 Regulating block	33	헥사곤 너트 Hexagon nuts	44	오일실 oli seal



### 3.2. 변속기성능표

### 3.2. STEPLESS SPEED VARIATOR SELECTION CHARTS

$P_1$ (kW)	$i$	TYPE	$n_2$ min <sup>-1</sup> max	$n_2$ min <sup>-1</sup> min	$M_2$ Nm min	$M_2$ Nm max	
0.18	1.6-8.2	UDL002	880	170	1.5	3	632-4
0.25	1.4-7	UDL005	1000	200	2	6	711-4
0.37	1.4-7	UDL005	1000	200	3	6	712-4
0.55	1.4-7	UDL010	1000	200	4.4	12	801-4
0.75	1.4-7	UDL010	1000	200	6	12	802-4
1.1	1.4-8.2	UD020	1000	170	9	18	90s-4
1.5	1.4-8.2	UD020	1000	170	12	24	90L-4
2.2	1.4-7	UD030	1000	200	18	36	100L1-4
3.0	1.4-7	UD030/050	1000	200	24	48	100L2-4
4.0	1.4-7	UD050	1000	200	32	64	112M-4
5.5	1.4-7	UD100	1000	200	45	90	132s-4
7.5	1.4-7	UD100	1000	200	59	118	132M-4

### 3.3. 입력축 도면

### 3.3. Input flange / shaft dimension

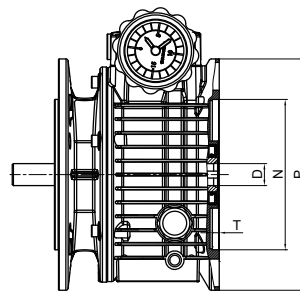
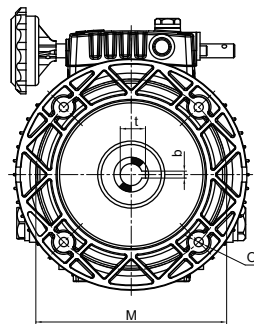

	PAM IEC	P	$N_{h7}$	M	O	$D_{E7}$	b	t	T
UDL002	63B5	140	95	115	M8	11	4	12.8	4
UDL005	71B5	160	110	130	M8	14	5	16.3	5
UDL010	80B5	200	130	165	M10	19	6	21.8	6
UD020	90B5	200	130	165	M10	24	8	27.3	6
UD030/050	100B5/112B5	250	180	215	M12	28	8	31.3	6
UD100	132B5	300	230	265	M12	38	10	41.3	6



### 3.4. 설치 포지션

### 3.4. MOUNTING POSITIONS

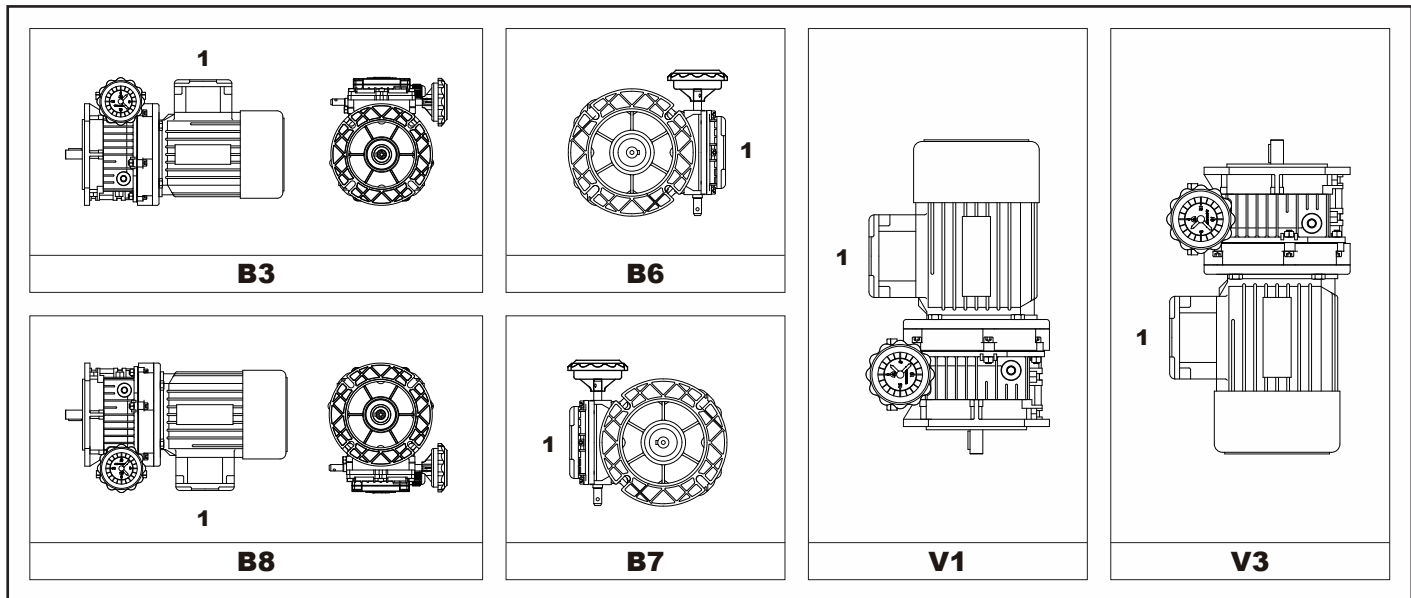

#### ▶ 포지션 다이어그램

#### ▶ POSITIONS DIAGRAM

핸드휠 포지션

Hand-wheel position

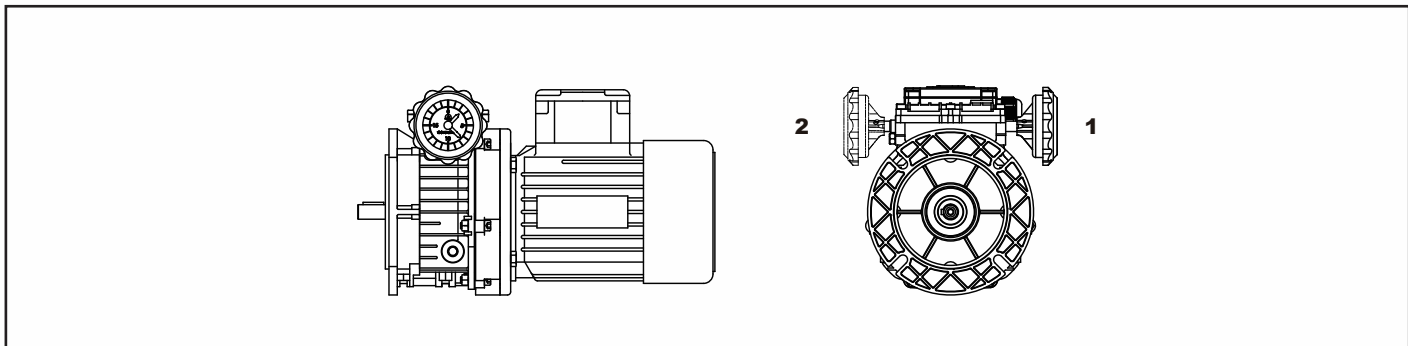

#### ▶ 단자박스 포지션

#### ▶ POS. of terminal box

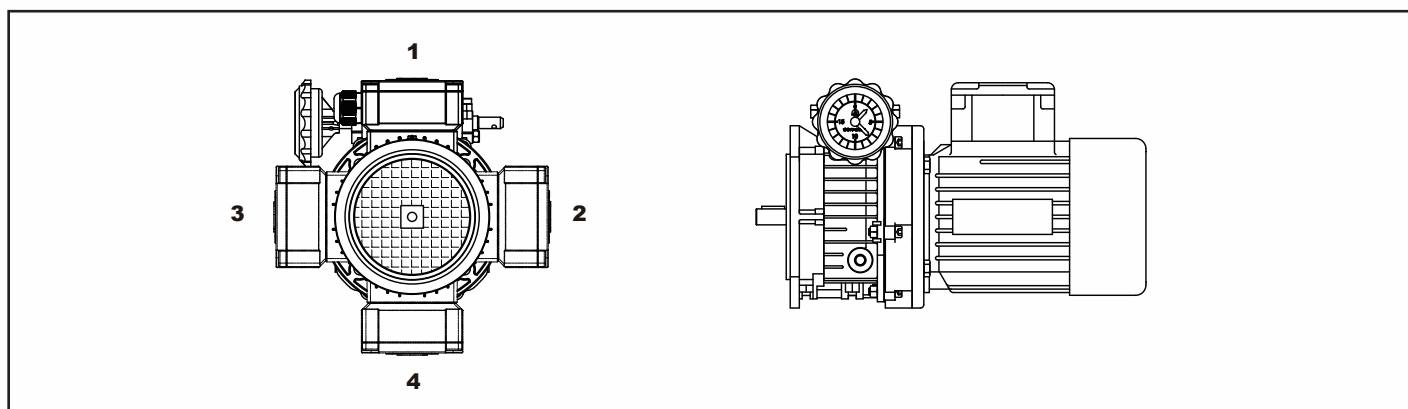

**UDL**

3.5. 변속기 도면

3.5. SPEED VARIATOR DIMENSIONS CHARTS

**UDL - B3**

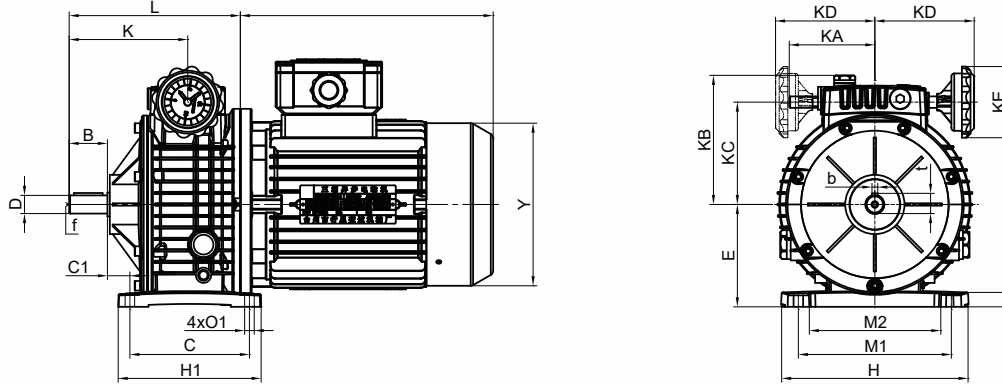

TYPE	B	Dj6	C	C1	E	h	h1	K	L	M1	M2	O1	KA	KB	KC	KD	KD1	KE	b	t	f	X	y	Z
UDL002B3-0.18	23	11	105	17.5	80	145	120	87	134.5	110	71	9	71	113	78	113	113	70	4	12.5	M5	207	130	10
UDL005B3-0.25	30	14	104	19.5	93	149	125	102	138.5	120	96	9	71	125	91	113	113	70	5	16	M5	225	145	10
UDL005B3-0.37																								
UDL010B3-0.55	40	19	125	35	113	190	150	127.5	183.5	160	135	11	79	142	107	120	120	85	6	21.5	M6	255	175	15
UDL010B3-0.75																								
UD020B3-1.1	50	24	140	49	125	230	170	154	221.5	180	130	13	-	148	127	140	-	85	8	27	M8	270	195	18
UD020B3-1.5																						295	195	
UD030B3-2.2	60	28	230	25	150	300	270	191	282	245	190	14	-	181	158	150	-	120	8	31	M8	325	215	25
UD030/050B3-3.0																						340	240	
UD050B3-4.0																						390	275	
UD100B3-5.5																						430	275	
UD100B3-7.5	80	38	250	32	200	365	290	200	333	315	225	18	-	218	193	182	-	120	10	41	M10	430	275	30

**UDL - B5**

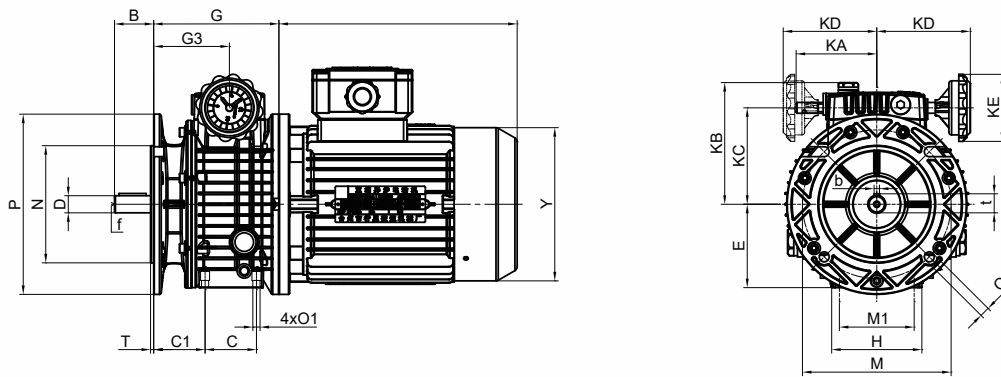

TYPE	B	Dj6	C	G	G3	E	h	M	M1	N	O	O1	P	T	C1	KA	KB	KC	KD	KD1	KE	b	t	f	X	y	Z
UDL002B5-0.18	23	11	50	111.5	64	70	72	115	60	95	9	M6	140	3.5	46	75	113	78	113	113	70	4	12.5	M5	207	130	
UDL005B5-0.25	30	14	40	108	71.5	80	90	130	77	110	9	M8	160	3.5	51.5	75	125	91	113	113	70	5	16	M5	225	145	
UDL005B5-0.37																											
UDL010B5-0.55	40	19	58	143.5	87.5	100	98	165	84	130	11	M8	200	3.5	62	82.5	142	107	120	120	85	6	21.5	M6	255	175	
UDL010B5-0.75																											
UD020B5-1.1	50	24	-	174	106.5	111	230	165	-	130	11	-	200	3.5	-	108.5	148	127	140	-	85	8	27	M8	270	195	
UD020B5-1.5																									295	195	
UD030B5-2.2	60	28	-	222	131	136	265	215	-	180	15	-	250	4	-	131	181	158	150	-	120	8	31	M8	325	215	
UD030/050B5-3.0																									340	240	
UD050B5-4.0																									390	275	
UD100B5-5.5																									430	275	
UD100B5-7.5	80	38	-	263	130	185	-	265	-	230	19	-	300	4	-	163	218	193	182	-	120	10	41	M10	430	275	

2.19. UDL + NMRV 도면

2.19. UDL + NMRV Dimensions charts

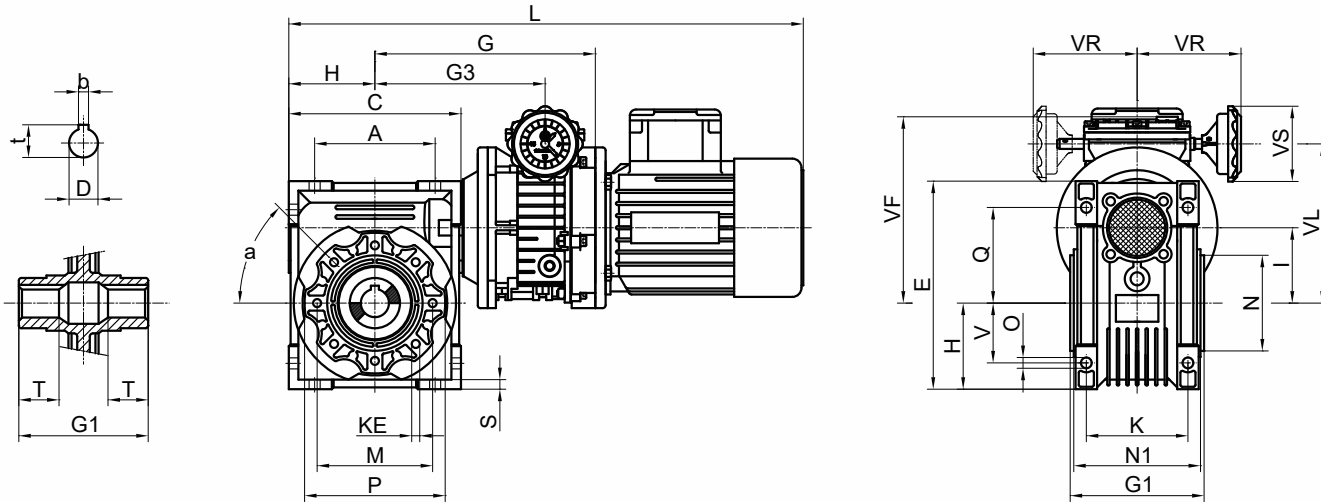

	A	C	D <sub>h8</sub>	b	t	E	G	G1	G3	h	i	L	M	N <sub>h8</sub>	N1	O	P	q	S	T	V	VF	VR	VS	VL	K	KE	a	
UDL002-NMRV040							181.5		134			438.5										153	113	70	118	60	M6x8	45°	
UDL005-NMRV040	70	100	18	6	20.8	121.5	178	78	141.5	50	40	453	75	60	73	6.5	87	55	6.5	26	35	165	113	70	131	60	M6x8	(n=4)	45°
UDL002-NMRV050							191.5		144			458.5										163	113	70	128	70	M8x10	(n=8)	45°
UDL005-NMRV050	80	120	25	8	28.3	144	188	92	151.5	60	50	473	85	70	87	8.5	100	64	7	30	40	175	113	70	141	70	M8x10	(n=8)	45°
UDL005-NMRV063							204		167.5			501										188	113	70	154	85	(n=8)		45°
UDL010-NMRV063	100	144	25	8	28.3	174	239.5	112	183.5	72	63	566.5	95	80	106	8.5	110	80	8	36	50	205	120	85	170	85	M8x14	(n=8)	45°
UDL010-NMRV075							256.5		200.5			597.5										217	120	85	182	90	M8x14	(n=8)	45°
UD020-NMRV075	120	172	28	8	31.3	205	287	120	219.5	86	75	668	115	95	114	11	140	93	10	40	60	223	140	85	202	90	M8x14	(n=8)	45°
UDL010-NMRV090							273		217			631										232	120	85	197	110	M10x18	(n=8)	45°
UD020-NMRV090	140	206	35	10	38.3	238	304	140	236.5	103	90	702	130	110	134	13	160	102	11	45	70	238	140	85	217	110	M10x18	(n=8)	45°
UDL010-NMRV105							303.5		247.5			686										252	120	85	217	115	M10x18	(n=8)	45°
UDL010-NMRV110																													
UD020-NMRV105	170	252.5	42	12	45.3	295	334	155	266.5	127.5	110	756.5	165	130	148	14	200	125	14	50	85	258	140	85	237	115	M10x18	(n=8)	45°
UD020-NMRV110																													
UD030-NMRV105												834.5																	
UD030-NMRV110																													
UD050-NMRV105							382		291			849.5										291	150	120	268				
UD050-NMRV110																													
UD020-NMRV130							354		286.5			796.5										278	140	85	257				
UD030-NMRV130	200	292.5	45	14	48.8	335	402	170	311	147.5	130	874.5	215	180	162	16	250	140	15	60	100	311	150	120	288	120	M12x21	(n=8)	45°
UD050-NMRV130							402		311			889.5										311	150	120	288				



오일

*Q.ty of oil in litres*

<b>UDL</b>	<b>UDL002</b>	<b>UDL005</b>	<b>UDL010</b>	<b>UD020</b>	<b>UD030/050</b>	<b>UD100</b>
<b>B3</b>	0.13	0.15	0.33	1.2	2	3.5
<b>B8</b>						
<b>B6-B7</b>						
<b>V1</b>	0.2	0.25	0.45	1.5	2.5	4
<b>V3</b>						